

Dual

# CS 1257



Operating Instructions

**Sehr geehrter Kunde,**

bitte lesen Sie vor der ersten Inbetriebnahme Ihres neuen Gerätes diese Anleitung sorgfältig durch. Sie bewahren sich dadurch vor Schäden, die durch falschen Anschluß oder unsachgemäße Bedienung entstehen können.

Die für die erstmalige Inbetriebnahme notwendigen Hinweise, sowie Erläuterungen zur Bedienung Ihres Gerätes finden Sie auf den Seiten 7 – 9. Eine Gesamtabbildung mit Kurzbeschreibung aller Bedienungselemente finden Sie auf den ausklappbaren Umschlagseiten.

Wir wünschen Ihnen nun viel Freude mit Ihrem Dual CS 1257.

**Cher ami mélomane;**

veuillez lire soigneusement cette notice avant la première mise en service de votre nouveau Dual afin d'éviter des dommages qui pourraient résulter d'un mauvais branchement ou d'une manipulation erronée.

Vous trouverez pages 9 – 12 des informations nécessaires pour la première mise en marche ainsi que des renseignements sur le fonctionnement de l'appareil. Une illustration de la platine ainsi qu'une description de tous les éléments de commande sont indiqués sur les pages de couverture qui sont à rabattre.

Nous vous souhaitons beaucoup de joie avec votre platine Dual CS 1257.

**Dear customer,**

please read these instructions carefully before you start using your Dual so that you will not encounter any problems resulting from faulty connections or handling.

However, you should read the instructions carefully before you operate the turntable for the first time. On pages 12 – 14 you will find detailed instructions for the operation of your unit. The first page is flapped and you will find a brief description of all control elements.

Good listening with your Dual CS 1257.

**Zeer geachte client,**

leest u voordat u het apparaat in bedrijf stelt eerst deze gebruiksaanwijzing zorgvuldig door. Hiermee voorkomt U schade aan het apparaat door onjuiste bediening of door onjuiste aansluiting.

De voor de eerste in gebruikname benodigde aanwijzingen vindt u op de pagina's 14 – 16. Een totaal-overzicht met korte beschrijving van alle bedieningselementen vindt u op de uitklapbare pagina.

Wij wensen u veel plezier met uw Dual CS 1257.

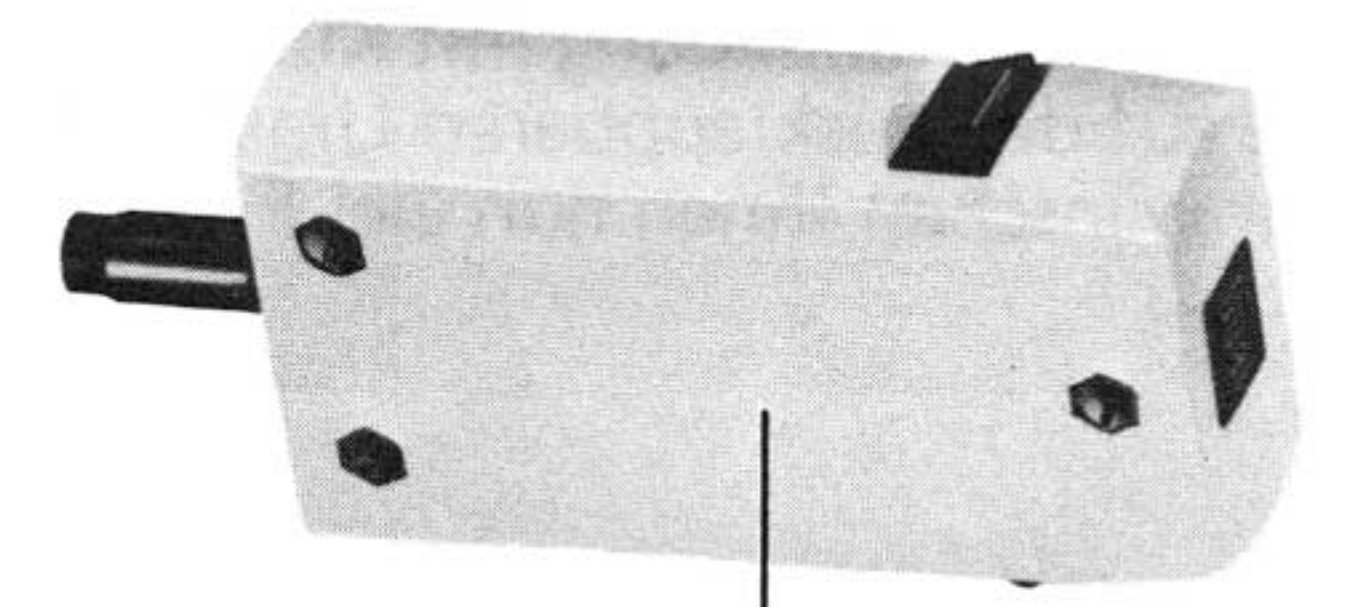

18



17

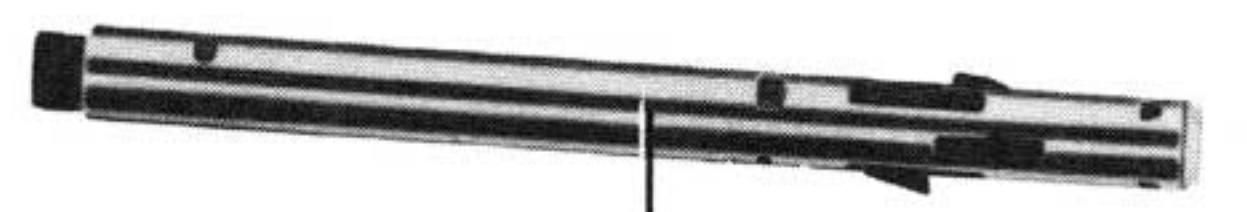

16

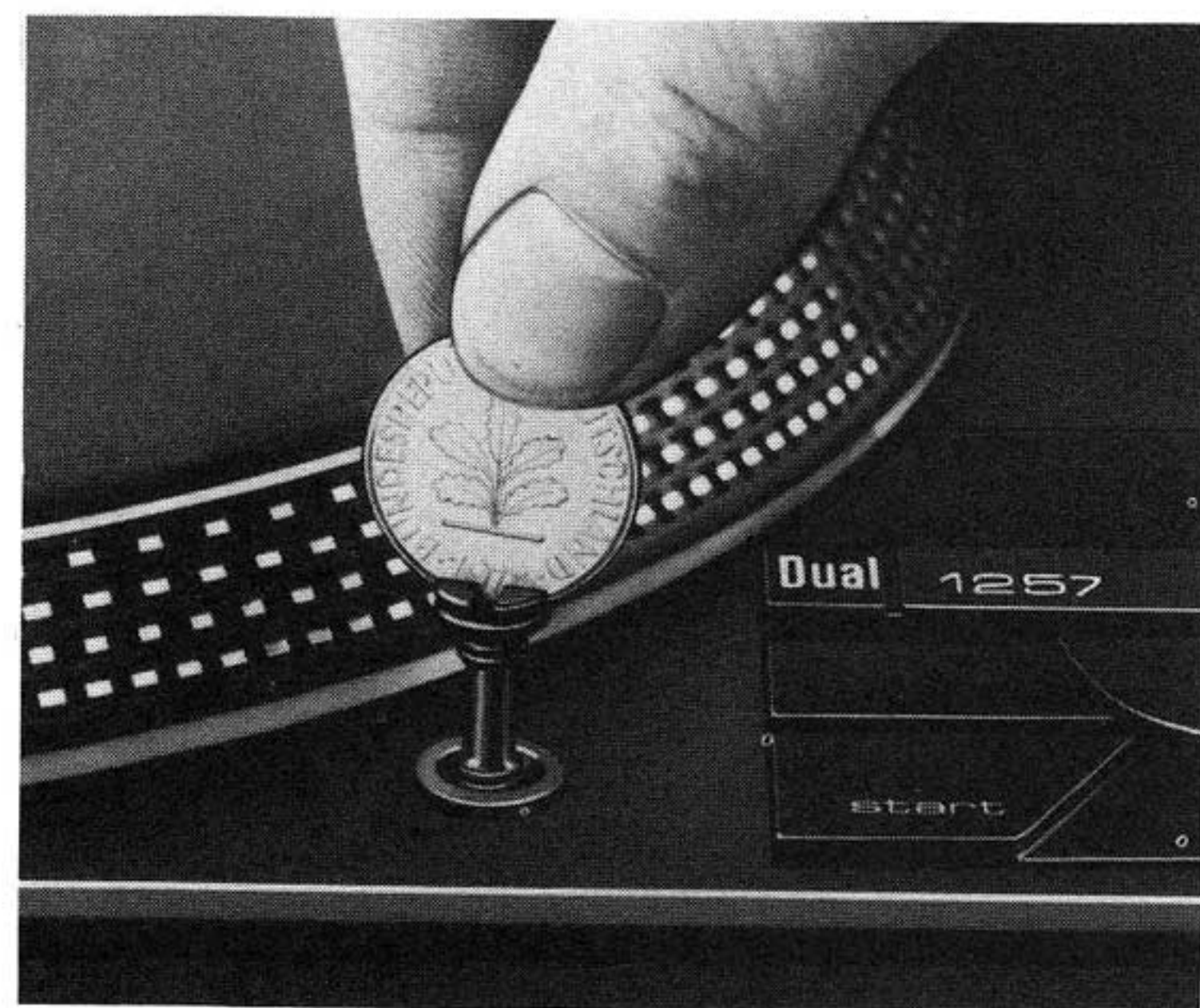

Fig. 1

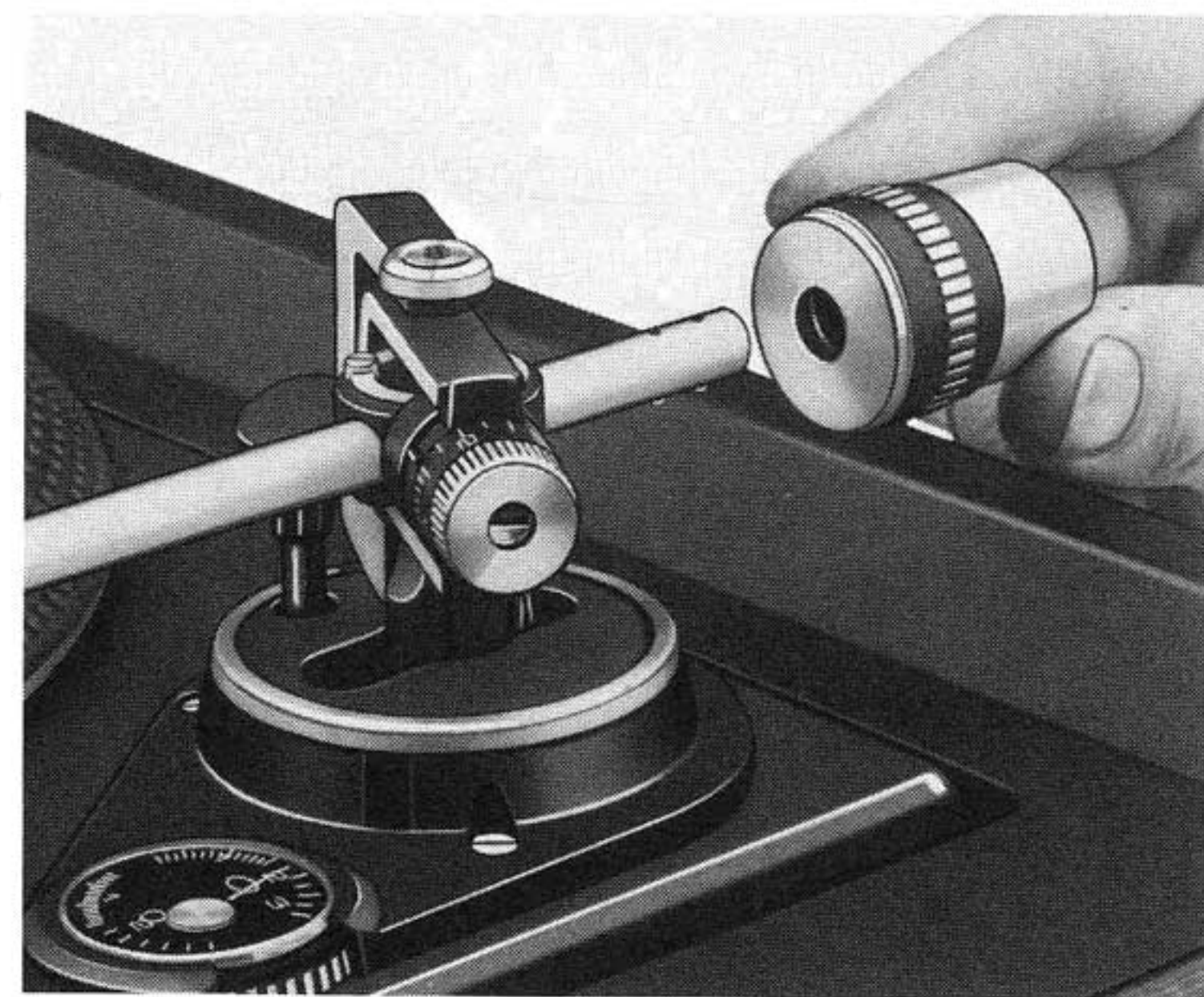

Fig. 2

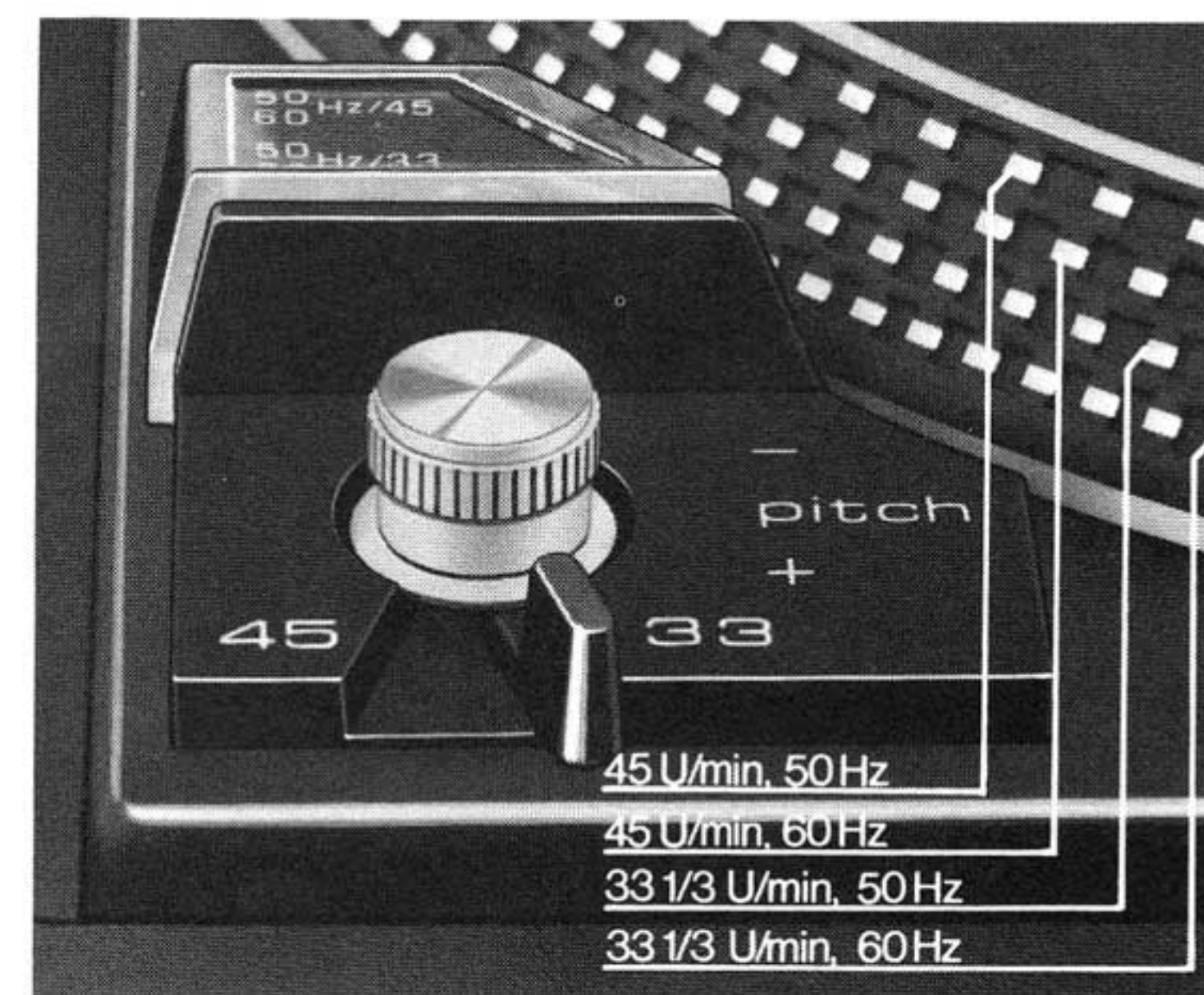

Fig. 3

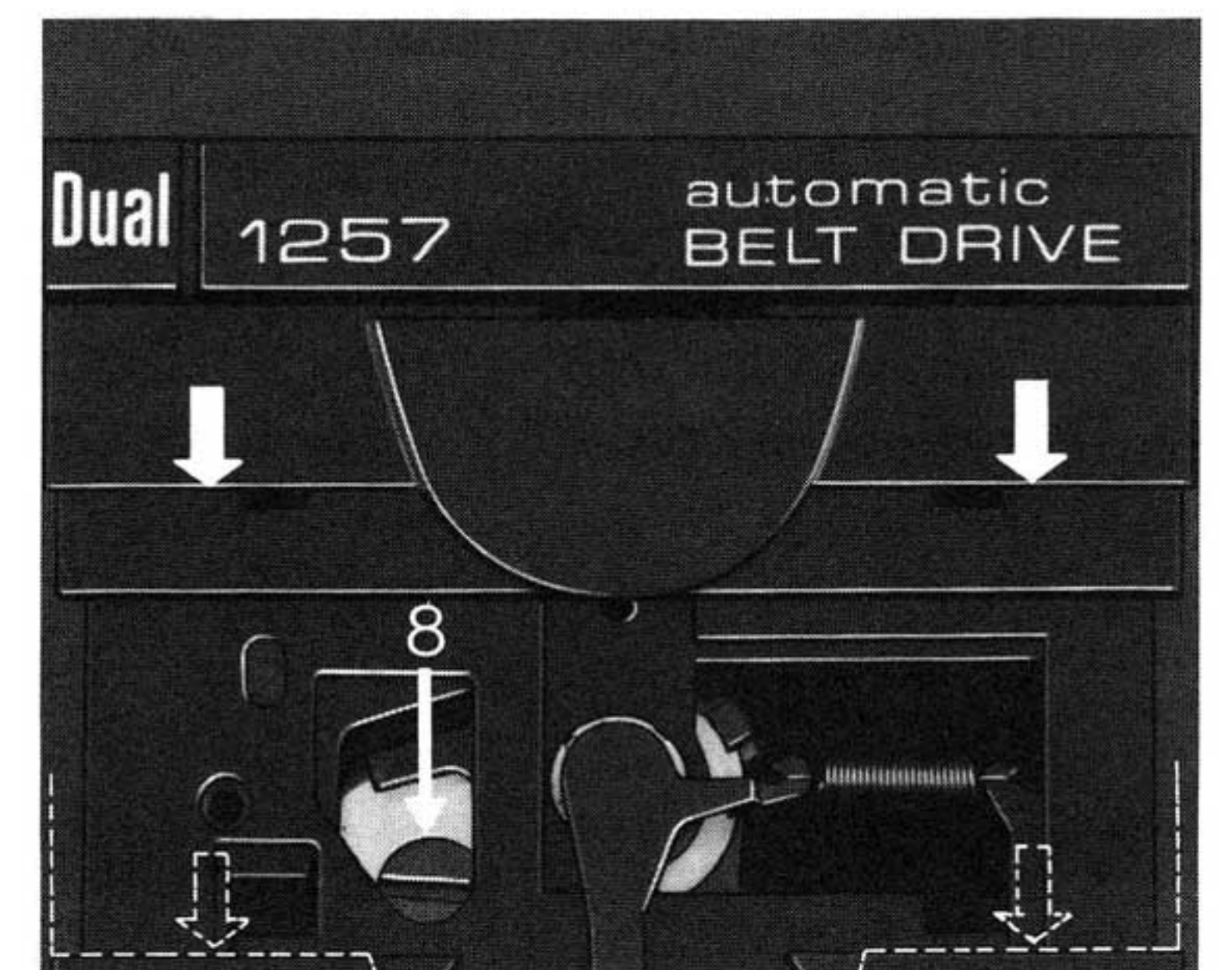

Fig. 4

## Die Bedienung

- (1) Tonarm-Balancegewicht
- (2) Tonarmauflagekraft-Einstellung
- (3) Antiskating-Einstellung
- (4) Justierschraube für Tonarmlift
- (5) Tonarmstütze mit Tonarmverriegelung
- (6) Tonarmlift
- (7) Steuertaste für "start" und "stop"
- (8) Justierschraube für Tonarmaufsetzpunkt (unter der Zierleiste)
- (9) Transportsicherungsschraube
- (10) Tonarmgriff  
Entnahmesicherung für Abtastnadel
- (11) Befestigungsschraube für Tonabnehmersystem
- (12) Mitlaufachse für Einzelspiel
- (13) Leuchtstroboskop
- (14) Plattenteller-Drehzahl-Einstellung
- (15) Tonhöhen-Abstimmung
- (16) Wechselachse AW 3
- (17) Zentrierstück für 17 cm-Schallplatten
- (18) Abwurfsäule AS 12 für 17 cm-Schallplatten

## Commandes de l'appareil

- (1) Contrepoids
- (2) Réglage de la force d'appui
- (3) Réglage de l'antiskating
- (4) Vis de réglage du lève-bras
- (5) Support du bras avec verrouillage du bras
- (6) Lève-bras
- (7) Manette de commande pour „start“ et „stop“
- (8) Vis de réglage du point de pose du bras (sous la réglette décorative)
- (9) Vis de sécurité pour le transport
- (10) Poignée du bras  
Protection pour l'aiguille de lecture
- (11) Vis de fixation pour cellule
- (12) Axe pour un seul disque
- (13) Stroboscope à lampe
- (14) Réglage de la vitesse
- (15) Réglage fin de la vitesse „Pitch“
- (16) Axe changeur AW 3
- (17) Centreur pour disques 45 t/min
- (18) Axe changeur AS 12 pour disques 45 t/min

## Operating

- (1) Tonearm counterweight
- (2) Stylus force setting
- (3) Anti-skating setting
- (4) Cue control height adjustment
- (5) Tonearm support with tonearm lock
- (6) Cue control
- (7) Automatic start - stop switch
- (8) Adjustment screw for tonearm set-down (below decorating cover)
- (9) Transport safety (hold down) screw
- (10) Tonearm lift  
Stylus lock
- (11) Cartridge attachment screw
- (12) Single-play spindle
- (13) Illuminated strobe
- (14) Speed selector
- (15) Pitch control
- (16) Multiple-play spindle AW 3
- (17) Adapter for large-hole records
- (18) Multiple-play spindle AS 12 for large-hole records

## Bedienung

- (1) Toonarm contragewicht
- (2) Naalddrukinstelling
- (3) Anti-skating instelling
- (4) Instelschroef voor toonarmlift
- (5) Toonarmsteun met
- (6) Toonarmlift
- (7) Start/stop toets
- (8) Instelschroef toonarmopzetpunt (onder de sierlijst)
- (9) Transportbeveiligingsschroeven
- (10) Toonarm handgreep  
Vergrendeling van de aftastnaald

- (11) Bevestigingsschroef voor aftaststelsysteem
- (12) Meeloopas voor normaal bedrijf
- (13) Verlichte stroboscoop
- (14) Toerentalinstelling platenspeler
- (15) Fijnregeling toerental
- (16) Wisselas AW 3
- (17) Centreerstuk voor 17 cm platen
- (18) Afwerpspindel AS 12 voor 17 cm platen

## El manejo

- (1) Contrapeso equilibrador del brazo fonocaptor
- (2) Ajuste de la fuerza de apoyo del brazo
- (3) Ajuste de la compensación del empuje lateral
- (4) Tornillo de ajuste del dispositivo de elevación/descenso
- (5) Soporte del brazo fonocaptor y bloqueo del mismo
- (6) Dispositivo de elevación/descenso del brazo
- (7) Tecla de mando para „start“ y „stop“
- (8) Tornillo de ajuste para punto de descenso del brazo (bajo la moldura)
- (9) Tornillo asegurador para transporte
- (10) Asidero del brazo/Dispositivo de seguridad contra extracción de la aguja lectora
- (11) Tornillo de fijación para sistema fonocaptor (cápsula)
- (12) Eje giratorio para reproducir discos individuales
- (13) Estroboscópio luminoso
- (14) Ajuste del número de revoluciones del plato giradiscos
- (15) Control de altura tonal
- (16) Eje cambiador AW 3
- (17) Pieza de centrado (adaptador) para discos de 17 cm
- (18) Columna lanzadora AS 12 para discos de 17 cm

## Beskrivning

- (1) Motvikt
- (2) Inställningsratt för nåltryckskraften
- (3) Antiskating-inställning
- (4) Inställningsskruv för tonarmsnedlägget
- (5) Tonarmsstöd med tonarmspärr
- (6) Tonarmsnedlägg
- (7) Start/stop-vred
- (8) Justerskruv för tonarmens nedläggningspunkt (ta bort prydnadslisten)
- (9) Skruv för transportsäkring
- (10) Tonarmsgrepp  
Säkrat fäste för nålen
- (11) Fästskruv för pickupsystemet
- (12) Medroterande centrumaxel
- (13) Belyst stroboskop
- (14) Varvtalsomkopplare
- (15) Tonhöjds kontroll (pitch)
- (16) Växlingsaxel AW 3
- (17) Adapter för 17 cm skivor
- (18) Växlingsaxel AS 12 för 17 cm skivor

## I comandi

- (1) Contrappeso del braccio
- (2) Ghiera di regolazione della pressione di lettura
- (3) Regolazione del dispositivo anti-skating
- (4) Vite di regolazione del dispositivo sollevabraccio
- (5) Supporto braccio con fermabraccio
- (6) Levetta del dispositivo sollevabraccio
- (7) Leva di comando per "start" e "stop"
- (8) Vite per la regolazione del punto di appoggio del braccio (sotto il listino decorativo)
- (9) Vite di fissaggio per il trasporto
- (10) Levetta fissaggio testina sicurezza contro un prelievo non autorizzato della puntina
- (11) Vite di fissaggio per la cartuccia
- (12) Perno centrale
- (13) Stroboscopio luminoso
- (14) Leva del cambio di velocità
- (15) Regolazione fine della velocità
- (16) Perno cambiadischi AW 3
- (17) Adattatore per dischi da 17 cm
- (18) Colonna cambiadischi AS 12 para dischi da 17 cm

# ENGLISH

## Unpacking and Installation

Take out the Styrofoam-protected platter assembly and put it aside for the time being. Remove the base with the turntable and place it where it will be used. Read carefully the special instruction sheet attached to the turntable before removing it and the packing material from the turntable.

Loosen the transit safety screws by turning them clockwise until they slide downward (about 15 mm) releasing the chassis from the base; then continue turning them clockwise to tighten the screws into the top of the chassis. The turntable is now in spring-supported position required for play position (B).

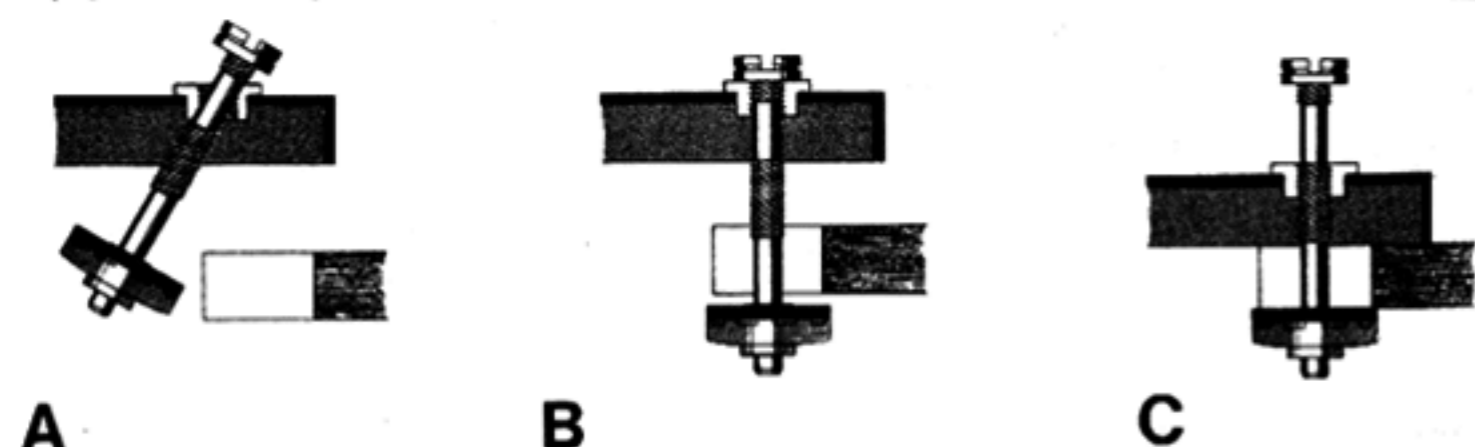

Take the tonearm counterbalance (1) from its styrofoam packing and screw it on to the rear end of the tonearm (Fig. 2). Page 13 explain how to balance the tonearm and adjust stylus pressure and anti-skating. The separate technical data sheet advises you on setting tracking pressure for the cartridge included with the unit.

Now connect the phono cables to the amplifier and connect the line cord either to the convenience outlet on the back of the amplifier or directly to the house current. Please read the separate instructions given for this phase of installation.

## Later Transport

Be sure the tonearm is locked and the stylus guard flipped down. Also, release the transport safety screws them counter-clockwise, then pull them up and tighten again by continuing to turn so as to secure the chassis against the base (C). The tonearm counterweight should be removed.

Should shipping of your Dual unit become necessary, make sure that the packing is adequate. Use, if possible, the original packing material in which you received your unit.

**Attention:** After each transport or installation, the unit must be started once with the tonearm in locked position for automatic adjustment of the shut-off mechanism. To initiate the automatic "Start" or "Stop" function, press the start switch all the way in each direction.

## Connection to AC Power Line

The unit can be operated on alternating current, 50 or 60 Hz, 110/125 or 220/240 V. At the factory, 50-Hz units are set for 230 V; 60-Hz units, for 115 V.

**If a different voltage supply and/or line frequency becomes necessary please consult your dealer or an authorized Dual Service Station.**

## Connection to the amplifier

The cartridge lead of your HiFi turntable is equipped at the works with RCA (cynch) jacks.

So that your receiver or reproducing amplifier be designed for DIN jacks, have your specialist dealer adapt this by replacing the complete cartridge lead.

Cartridge lead with DIN jack 1.10 m long.

Order number 207 303.

Dual cartridge leads can also be equipped for plug-in into the turntable.

Please do not forget to connect the chassis lines of the right hand (green) and left hand (blue) tonearm lines to the chassis of the unit when converting this from cynch (RCA) to DIN jacks.

An equalized-amplifier is necessary if your stereo amplifier or receiver has no direct input for magnetic cartridge systems. In this case, we recommend the Dual TVV 47 which is equipped with plug-in connections.

## Dust Cover

This simplifies operation of record player and also facilitates accommodation of the complete unit in bookshelves, consoles etc.

For placing the dust cover turn the unit in such a manner that the special hinges are readily accessible. Make sure that the receiving sections of the hinges into which the cover shall be pushed in are correctly positioned (tilted at 60°) before the dust cover is paralleled to the position of the receptors and depressed.

In this position the dust cover can be removed completely.

For adjustment of spring relief (the cover is kept by spring power in its position) turn both knurled screws.

Adjust screws in the same manner. In most cases half a turn will be sufficient.

## Start and Operation

First select the correct platter speed, then unlock tonearm. If the cartridge has a stylus tip protector, move it upward.

### 1. Automatic start

Indexing is interlocked with the speed selector, so the tonearm will set down into the lead-in groove of 12" (30 cm) records when switched to 33 1/3 rpm, and into the lead-in groove of a 7" (17 cm) record when set to 45 rpm. To initiate "start" function, press the switch (7) all the way. The switch returns to its original position immediately after its release. The tonearm moves to the record, lowers slowly and sets the stylus gently in the lead-in groove of the record.

### 2. Manual start

- Move cue control lever (6) to position ▾.
- Move tonearm by hand over the desired point on the record.
- Tape control lever to position ▾.

### Attention!

With the cue control lever in position ▾ and automatic start, the tonearm moves to the setdown position. By tapping the control lever the tonearm will descend to the record.

The height of the stylus tip over the record when the tonearm is in the raised position by the cue-control can be varied about approx. 6 mm by turning the adjustment screw (4).

### 3. If a record is to be played repetitively or played once more from the start

Move switch to „start“.

### 4. Interrupting play (Pause)

Set the cueing lever to position ▾. When the cueing lever is returned to position ▾, playing is continued. The last few notes before the pause are repeated.

### 5. Shut-off

Move switch to position „stop“.

The tonearm will return to its rest position and the unit will shut off automatically.

**Note:** For records with other diameters, such as 25 cm records, the unit is operated manually. See Section "2. Manual start".

After the record has been played, shut-off and tonearm return is automatic irrespective of having started the unit manually or automatically. The tonearm should then be locked and the stylus tip protector moved down again.

### Automatic record change

(For 30 cm records/33 1/3 rpm or 17 cm records/45 rpm only).

Insert the changing spindle **(16)** or the automatic changer spindle **(18)\*** so that pin fits into the slot in the shaft.

Secure the spindle or automatic changer spindle in place by pressing down on it and turning it to the right until it stops. Load up to six records of either 17 cm 45 rpm or 30 cm 33 1/3 rpm, on the spindle or automatic changing spindle.

Move the operating switch to „start“. This will cause the first record to drop and the tonearm to be set down in the lead-in groove. Should you want to interrupt any record and cause the next to drop, move the operating switch to „start“.

**Note:** Records already played can be lifted back onto the spindle platform for replay or removed entirely. The spindle need not be removed.

\* It depends on whether the automatic changer spindle and changing spindle are special accessories or have been added to the unit as standard accessories.

### Balancing the tonearm

Precise tonearm balance is most important for cartridges having a low stylus pressure. Balancing need only be done once. We recommend, however, that you occasionally check the tonearm balance.

The pick-up arm is correctly balanced if it remains in a horizontal position when released, i.e. if it does not rest against the lower or upper end stops and if it returns to a horizontal position if deflected vertically by a small amount. The tonearm is balanced exactly by turning the counterbalance weight **(1)**.

1. With the pick-up arm still locked on the arm support, turn the turntable a few revolutions in a clockwise direction by hand.
2. Set the tracking force **(2)** and anti-skating **(3)** controls to „zero“ (with the pointer L/H), unlock the tonearm, and lift it from the tonearm rest.
3. Should the tonearm not come to rest horizontally, balance the tonearm exactly by turning the counterweight (see above).
4. Adjust tracking force and anti-skating.

### Setting the Stylus Pressure

Each cartridge has an optimum stylus pressure. See instructions supplied with your cartridge.

Once the tonearm is balanced exactly, the stylus pressure is set to the recommended value for the cartridge by turning the stylus force scale **(2)**. The stylus pressure can be set to any value from 0 – 30 mN (0 - 3 g) whereby the figures on the scale are to be interpreted as follows.

- 1 = 10 mN  $\triangleq$  1 g
- 2 = 20 mN  $\triangleq$  2 g
- 3 = 30 mN  $\triangleq$  3 g

The unit is designed to operate with stylus pressures from 5 mN (0.5 g).

### Antiskating

The skating force which acts upon any pick-up arm causes one-sided wear on the needle and on the record and can cause distortion in the reproduction.

To compensate for skating force, a counterforce, precisely defined in weight and direction, must be applied to the tonearm. The anti-skating mechanism **(3)** of your turntable fulfills this requirement.

Separate calibrations are provided for the stylus types used almost exclusively today, according to the imprinted symbols:

- setting for conical stylus
- setting for biradial (elliptical) styli

The setting of anti-skating compensation corresponds to the setting of stylus pressure: Turn the anti-skating knob to the number on the appropriate scale which corresponds to the stylus pressure you have set. That is, for a stylus pressure of 15 mN (1.5 grams), set the anti-skating knob also at „1.5“. When playing records moistened with a cleaning agent, the skating force is reduced by approximately 30%. In such cases we recommend a corresponding 30% decrease in antiskating compensation.

### Stylus

For above subject refer to „Notes on pick-up cartridge of your unit“ attached to the Operating Instructions.

In normal use, every stylus is subject to wear and tear. We recommend that it be inspected occasionally, but certainly after approximately 300 playing hours in case of diamond styli. Your Dual dealer will do this without charge. Worn or damaged (chipped) styli will grind the modulation out of records grooves and damage the records. In case of replacement, obtain only the stylus type recommended in the Technical Data for the cartridge. Imitations cause noticeable loss in sound quality and rapid record wear.

Please keep in mind that the stylus holder with the diamond tip is necessarily quite delicate in order to provide quality performance. It is, therefore, extremely sensitive to harsh handling, accidental touch, blows, etc. Take the cartridge in the holder to your Dual dealer for inspection of the stylus.

### Pitch control

Each of the two standard speeds (33 1/3 and 45 rpm) can be varied with the pitch control. Adjustment is made with pitch control knob **(15)** (Fig. 3). Adjustment range at 33 1/3 rpm approx. 1 semitone (6%).

The pitch control maintains the nominal speed and provides for individual control of tempi and pitch of reproduction, for example, when the pitch of recorded music is to match a live musical instrument, or when a record passage is to match the length of a motion picture scene.

The selected turntable speed can be checked with the aid of the stroboscope on the outer edge of the turntable. If this is illuminated with a light operating on alternating current, then the scale of circular dots for the required turntable speed appears to stand still – although the turntable is moving – if the speed of the turntable is accurately adjusted.

### Removing the platter

The platter is secured by the connection of the central ornamental ring. To remove the platter press the ring slightly downward and turn it approximately 60° to the right until it noticeably releases. The platter can now be removed.

To secure the platter replace the ornamental disc press it down slightly and turn it approximately 60° to the left.

### Replacing the drive belt

In order to replace the drive belt, the platter must be removed (see section „removing the platter“).

Remove the flat belt from the drive pulley and platter pulley and place the new precision flat belt on the belt surface of the platter pulley.

**Important!** The matt (polished) side must face inwards!

Lift the flat belt (if necessary with a strip of cardboard) from the pulley surface and place it over the drive pulley of the motor. Make sure that the flat belt runs within the guide fork without touching.

### Adjustment of Tonearm indexing

If playing of a record is started automatically, the pickup needle is lowered automatically into the run-in groove of the record.

If the stylus of another cartridge, installed later, sets down too far inside or outside the lead-in groove, adjustment can be made as follows:

Move the speed selector to "33". Removing the decorating strip (first lift it on the rear edge) will expose the control (8) for tonearm indexing (Fig. 4).

Place a 12" record on the platter and start the unit. If the stylus sets down too far inside or outside the center of the record, turn adjusting screw clockwise or counterclockwise, respectively. Turn the adjusting screw clockwise or anticlockwise until the pickup needle is lowered accurately into the starter groove.

## 50 or 60 Hz Line Frequency

Conversion to a different power line frequency is accomplished by exchanging the motor drive pulley.

60 Hz AC current is generally supplied in overseas countries. Ask your dealer, if necessary.

## Service

All lubrication points are adequately supplied with oil prior to delivery to the customer. Under normal conditions, your Dual unit should function properly for many years; do not oil any part of your Dual turntable yourself. Should your player ever require service, please take it to your Dual dealer, or ask him for the address of the nearest authorized Dual service station. Please make sure that only original Dual replacement parts are used. Should shipping of your Dual become necessary, make sure the packing is adequate. Use, if possible, the original packing material in which you received your Dual.

## Electrical safety

This player meets international safety standards for radio and related equipment (IEC 65).

## Technical data

Measured values = typical values.

Rumble and wow and flutter values obtained with test record.

**Current** AC 50 or 60 Hz, can be converted by replacing the drive pulley and the electronic system of the motor.

## Line Voltages

115 and 230 V, changeable

## Drive

Dual 16-pole synchronous motor: precision flat belt for flywheel drive

## Power consumption

approx. 8 watts

## Platter

aluminium section platter 270 mm  $\phi$ , 0.9 kg

## Platter speeds

 33 1/3 and 45 rpm

Automatic tonearm set-down coupled with speed adjustment

## Pitch Control Variation

at both platter speeds.

Adjustment range at 33 1/3 rpm approx. 1 semitone (6 %).

## Total Wow and Flutter

According to DIN 45 507 (German Industry Standard)  $\pm 0.08$  %  
WRMS  $\pm 0.05$  %

## Rumble (according to DIN 45 507)

Unweighted 46 dB  
Weighted 68 dB

**Tonearm** Torsionally rigid tubular aluminum tonearm in low-friction four-point gimbal suspension.

## Tonearm bearing friction (related to stylus tip)

vertical 0.08 mN (0.008 g)

horizontal 0.16 mN (0.016 g)

## Stylus Pressure

from 0 - 30 mN (0 - 3 g) infinitely variable, operable from 5 mN (0.5 g) stylus pressure up

**Cartridges** with 1/2 inch screw-type attachment. These can be fitted with the special accessories no. 261 865 which can be obtained from trade dealers. Adjustable Overhang 5 mm.

## Cartridge

See separate data sheet